



**DOWNLOAD THE LATEST
INSTALL MANUALS AT
www.bddiesel.com**



BD PERFORMANCE DODGE 5.9L CUMMINS
EXHAUST MANIFOLD

-- Installation Instructions --

Application List		
1045987	2003-2007	Dodge 24V

-- PLEASE READ ALL INSTRUCTIONS BEFORE INSTALLATION --

**** Important notice on page 3 ****

**1045987 can be used as a direct replacement for Cummins part numbers 3967995,
3943871 & 3943875.**

BD Engine Brake Inc.

Plant Address: 33541 MacLure Rd. Abbotsford, BC, Canada V2S 7W2





U.S. Shipping Address: 88-446 Harrison St, Sumas, WA 98295 U.S. Mailing Address: P.O. Box 231, Sumas, WA 98295

Phone: 604-853-6096 | Fax: 604-853-8749 | Internet: www.bd-power.com

KIT CONTENTS:

Please check to make sure that you have all the parts listed in this kit **before** you start the disassembly of your truck.

1045987 – Dodge 2-piece Exhaust Manifold (2003-07)			
1405990R-M / 1405990F-M	1 405981	1405982	1200208
			
Front & Back Manifold Assembly	M10x35mm S/S Bolt	10mm S/S Washer	1/8" NPT Plug
Qty: 1	Qty: 1	Qty: 1	Qty: 2

1405998	1100110	1100111	1100112	1100113
				
Coolant Bracket	1/4" Bolt	1/4" Flat Washer	1/4" Lock Washer	1/4" Nut
Qty: 1	Qty: 1	Qty: 1	Qty: 1	Qty: 1

1462430	1462431	1462441
		
M10 x 1.5 x 030 Stud	M10 x 1.5 x 025 Stud	Nut M10 -1.5
Qty: 2	Qty: 2	Qty: 4

Manifold Joints

BD manifolds use precision, tight tolerance, slip fit expansion joints. These joints reduce stress from thermal expansion and contraction in use. This relieves stress in both the manifold and engine head. Please note this type of joint will slide by hand allowing a simple and easy installation.

How does this joint seal? The internal section is closer to the high temperature exhaust gasses, this heat expands the internal section of the joint more than the larger external section which is cooled by its surroundings. The slip fit then fully seals as soon as EGTs are above 100-200 Deg F.

Options

<u>Description</u>	<u>Part #</u>
24V Exhaust Manifold Gasket Set	1045986

ATTENTION!

YOUR MANIFOLD IS COATED WITH A CERAMIC BASED PAINT. THE PAINT WILL NEED AT LEAST ONE HEAT CYCLE TO FULLY CURE. UNTIL THEN, THE PAINT WILL BE SOMEWHAT SOFT AND WILL BE EASY TO SCRATCH.

TO HEAT CYCLE THE MANIFOLD, ALLOW THE VEHICLE TO IDLE FOR ABOUT 15 MINUTES, AND THEN LET THE MANIFOLD COOL TO AMBIENT TEMPERATURE.

SCRAP OFF ANY EXCESS PAINT ON THE GASKET MATING SURFACES. A THIN COAT WILL NOT AFFECT THE SEALING PROPERTIES.

BD Engine Brake Inc.

Plant Address: 33541 MacLure Rd. Abbotsford, BC, Canada V2S 7W2

U.S. Shipping Address: 88-446 Harrison St, Sumas, WA 98295 U.S. Mailing Address: P.O. Box 231, Sumas, WA 98295

Phone: 604-853-6096 | Fax: 604-853-8749 | Internet: www.bd-power.com

Installation

Disconnect both battery ground cables.

Remove the intake air hose from the front of the turbo and set to the side. You can also remove the air box to aid in additional room.

Remove the V-band clamp that connects the turbo elbow casting to the exhaust down pipe.

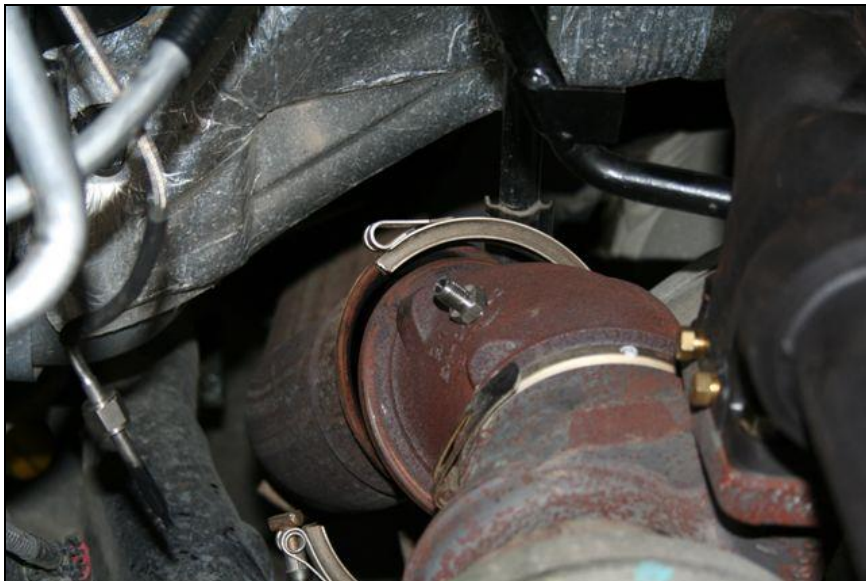

Disconnect the compressor outlet boot.



Disconnect the turbo oil supply and the turbo oil drain.



Using a cutoff wheel, cut the coolant line support bracket about 1-1.5" from the coolant tube. Leave enough material to re-connect the new supplied bracket to this tab.

This technique should save you approximately 1 hour of installation time and eliminate the need to drain the coolant.

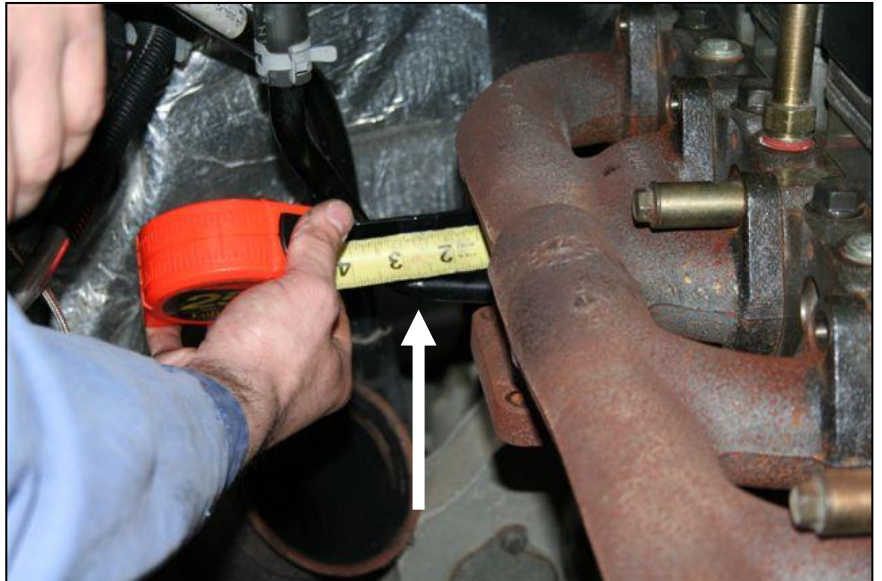

Remove the factory heat shield that covers the front of the manifold.

Remove the factory manifold and turbo assembly. Be sure to save the OE bolts and spacers as you will be reusing them.

Once the factory manifold is removed, clean the head surface of any carbon or soot build up.



With the manifold and turbo assembly on the bench, remove the turbo.

Remove the factory studs from the OEM manifold and discard them. Place the provided **M10 x 1.5 x 30mm (1462430)** studs into the manifold.



Remove factory studs from the turbo and discard. Install the provided **M10 x 1.5 x 25mm (1462431)** studs into the turbo.

Re-install the turbo onto the manifold, using the supplied M10-1.5 nuts. (1462441)

Don't forget to install a new gasket between the turbo and manifold. It does not matter which way the ridge on the gasket faces.



BD Engine Brake Inc.

Plant Address: 33541 MacLure Rd. Abbotsford, BC, Canada V2S 7W2

U.S. Shipping Address: 88-446 Harrison St, Sumas, WA 98295 U.S. Mailing Address: P.O. Box 231, Sumas, WA 98295

Phone: 604-853-6096 | Fax: 604-853-8749 | Internet: www.bd-power.com

With the whole assembly tight, re-install it to the engine.

Be sure to install a new gasket for each cylinder. It does not matter which way the ridge on the gasket faces.

Torque the bolts to **35 lbs-ft.**

Note that you may need to align the front or rear manifold to match the threaded holes on the cylinder head. You can use a rubber mallet to do this.

When installing the lower bolt to cylinder #5, discard the factory bolt and spacer. Place the coolant pipe bracket against the manifold and install the **M10 SS socket head bolt (1405981)** and the **M10 Washer (1405982)** to secure the bracket and the manifold to the head.

Before tightening the bolt, line up the bracket to the OEM coolant pipe tab that you cut earlier.

Torque the bolt to **35 lbs-ft.**

Note: On 2006 model year vehicles, you will need to secure the bracket to cylinder # 6.

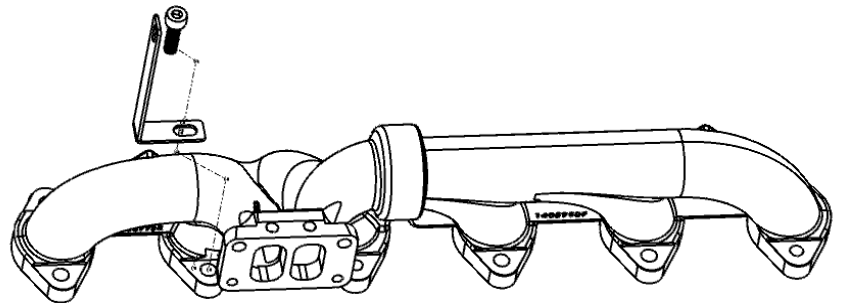

BD Engine Brake Inc.

Plant Address: 33541 MacLure Rd. Abbotsford, BC, Canada V2S 7W2

U.S. Shipping Address: 88-446 Harrison St, Sumas, WA 98295 U.S. Mailing Address: P.O. Box 231, Sumas, WA 98295

Phone: 604-853-6096 | Fax: 604-853-8749 | Internet: www.bd-power.com

You now have the option to drill a hole through the OEM coolant pipe tab and secure the brackets together using the ¼ bolt (1100110), ¼" flat washer (1100111), ¼" lock washer (1100112), and the ¼" nut (1100113) supplied. Use a 5/16" drill bit to accomplish this.

Or, you can spot weld the bracket and the OEM coolant pipe tab together.

If you choose to weld, be sure to paint the weld after.

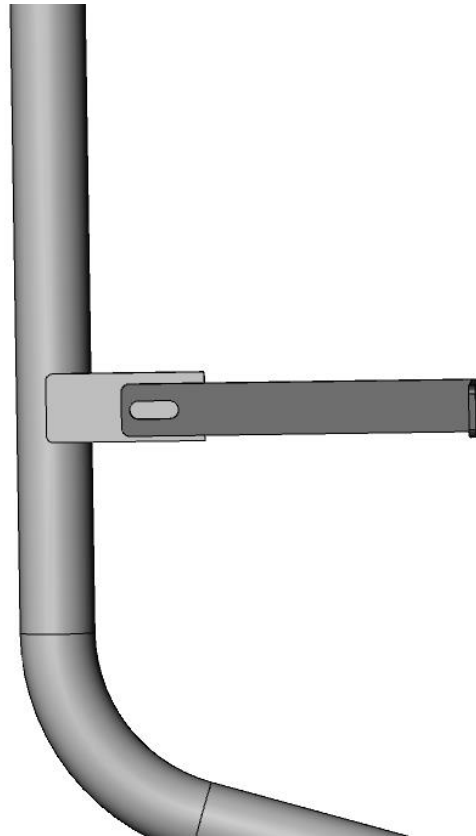

Once that is secure, you can now reconnect the V-band clamps from the exhaust pipe to the turbo exhaust elbow and the compressor outlet.



Reconnect the turbo oil drain and oil supply.

Reconnect the air inlet pipe to the front of the turbo and re-install the air box if you had removed it.

RE-TORQUE ALL BOLTS AFTER AT LEAST ONE HEAT CYCLE

BD Engine Brake Inc.

Plant Address: 33541 MacLure Rd. Abbotsford, BC, Canada V2S 7W2

U.S. Shipping Address: 88-446 Harrison St, Sumas, WA 98295 U.S. Mailing Address: P.O. Box 231, Sumas, WA 98295

Phone: 604-853-6096 | Fax: 604-853-8749 | Internet: www.bd-power.com