



**DOWNLOAD ENHANCED  
INSTALL MANUALS AT  
*dieselperformance.com***



## **GMC Duramax (LLY) High Idle Kit**

Note: Only for automatic transmissions with cruise control

1036605

2004-2005 GMC Duramax

**PLEASE READ ALL INSTRUCTIONS BEFORE INSTALLATION**

BD ENGINE BRAKE, INC.

Plant Address: A10-33733 King Rd, Abbotsford, BC, Canada V2S 7M9





US Shipping Address: 88-446 Harrison St, Sumas, WA 98295 US Mailing Address: PO Box 231, Sumas, WA 98295

Phone: 604-853-6096 Fax: 604-853-8749 Internet: [www.bd-power.com](http://www.bd-power.com)

# KIT CONTENTS

Please check to make sure that you have all the parts listed in this kit before you start.

<b>1036605 High Idle Kit</b>	
	<p><b>15356827</b></p>
<p><i>Wiring Harness</i></p>	
<p><b>Qty: 1</b></p>	<p><i>Spare LLY ECM Terminal</i></p> <p><b>Qty: 1</b></p>

<p><b>1330155</b></p>	<p><b>1300131</b></p>	
		
<p><i>1/4" Loom</i></p>	<p><i>Medium Tie Wrap</i></p>	
<p><b>Qty: 90"</b></p>	<p><b>Qty: 6</b></p>	
	<p><b>1300337</b></p>	<p><b>1003332</b></p>
		
	<p><i>Mini Fuse Tapper</i></p>	<p><i>Switch Decal</i></p>
<p><b>Qty: 1</b></p>	<p><b>Qty: 1</b></p>	<p><b>Qty: 1</b></p>

## Tools Required

- Drill with stepper drill bit
- Utility Knife
- Small flat screwdriver or pick
- 7mm & 10mm Sockets
- Ratchet with extension

## Introduction

This high idle kit allows the operator to enable the high idle programming within the Duramax ECM. In conjunction with the cruise control switches, the operator may select different RPMs for fast idle.

This kit is perfect for faster warm ups, extended idling and PTO applications.

## INSTALLATION



**VEHICLE SHOULD BE SAFELY SECURED BEFORE INSTALLATION.**

Disconnect both batteries for safety.

Remove trim surrounding instrument cluster by gently pulling out the clips. This may be eased by tilting the steering wheel downwards and moving the shift lever from park to 1<sup>st</sup>.



Remove fuse cover from end of dash. Remove knee bolster by removing the two 7mm screws along bottom edge, and then pull knee bolster outwards. Use care not to damage the clips.

Position toggle switch near the desired location keeping sufficient wire slack. Feed the wires below the dash.



BD ENGINE BRAKE, INC.

Plant Address: A10-33733 King Rd, Abbotsford, BC, Canada V2S 7M9

US Shipping Address: 88-446 Harrison St, Sumas, WA 98295 US Mailing Address: PO Box 231, Sumas, WA 98295

Phone: 604-853-6096 Fax: 604-853-8749 Internet: [www.bd-power.com](http://www.bd-power.com)

Remove the cruise control fuse from the in cabin fuse panel and install fuse tapper. Reinstall fuse with tapper on the right side of the fuse (towards the rear of the vehicle).

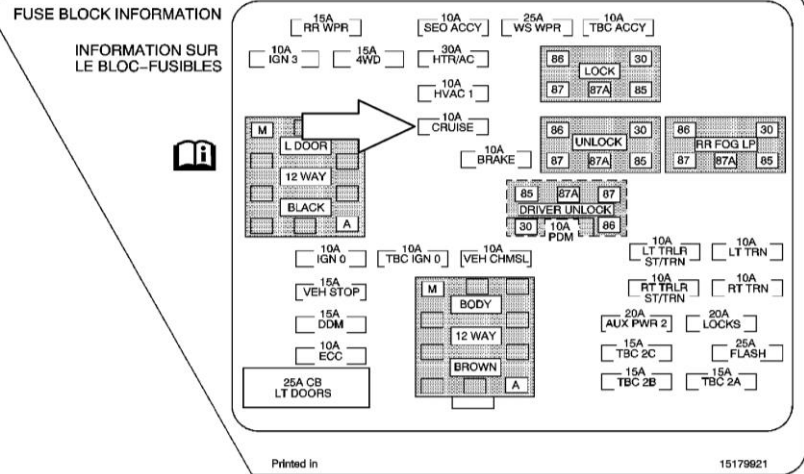

Route the red wire to the fuse box and connect to the fuse tapper

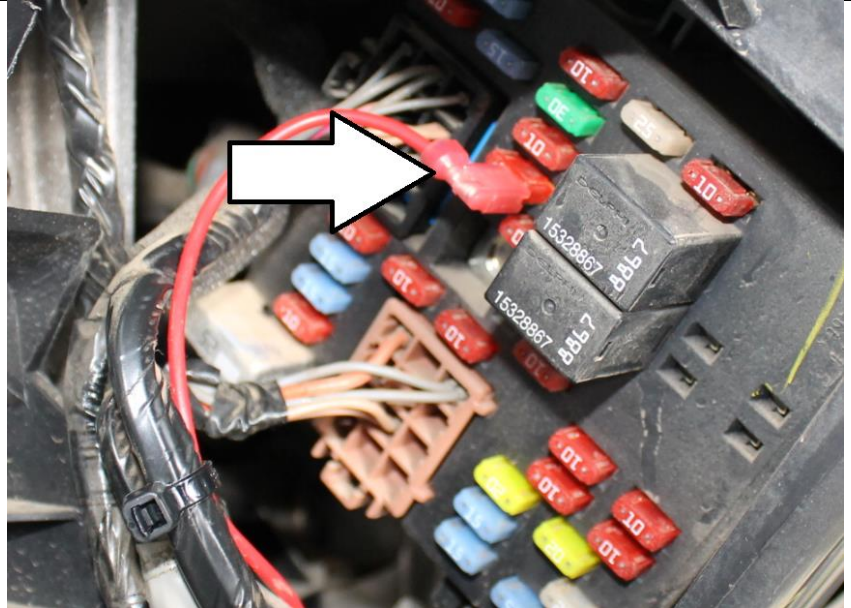
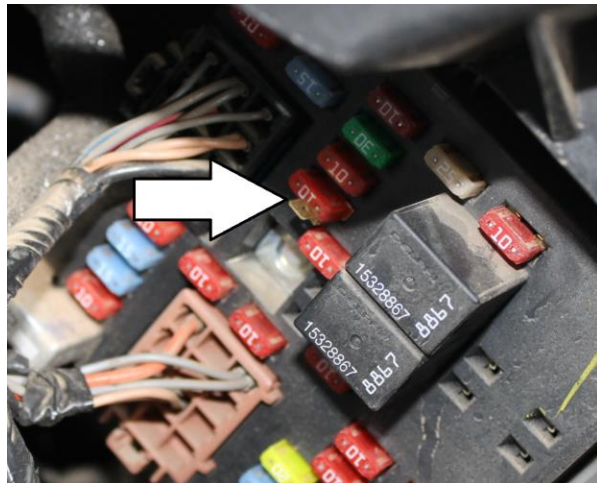

Route the black wire to the head of a bolt below the dash to serve as a ground. Remove the bolt using a 10MM socket and ratchet, install ring terminal and reinstall the bolt.

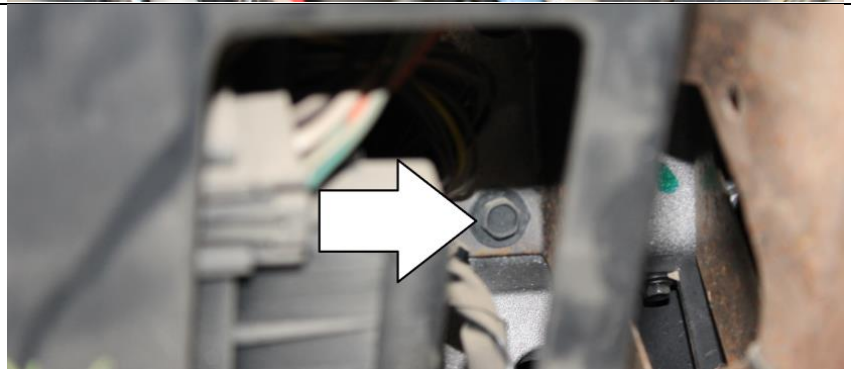

Locate suitable pass through location on firewall. Suggested location is alongside the smaller wiring harness passing through the firewall, this is located towards the passenger side of the brake booster assembly. Cut a small slit in the rubber boot using a utility knife for the wire to pass through. Alternatively, if other wires are already fed through the main wiring harness connector below the brake booster, this route may be used instead. Feed the yellow wire from the switch through the firewall. Use care not to damage the pin while being pushed or fished through the rubber grommet as it is fragile. If the grommet being utilized is tight, do not damage the pin, either enlarge the hole or cut the wire and rejoin it afterwards.

Locate the ECM on the driver's side of the vehicle below the battery. Disconnect the lowest of the three connectors from the ECM by releasing the locking handle.



Rotate the connector so that you can remove the back plastic protective backing. Use a small pick of small screwdriver to do this.

Using a small screwdriver or pick, remove the plastic blank from pin number 6.

Insert the yellow wire from the BD high idle kit into pin number 6.

One spare terminal has been supplied with this kit in case the terminal is damaged during installation. Discard if not needed. (PN: 15356827)

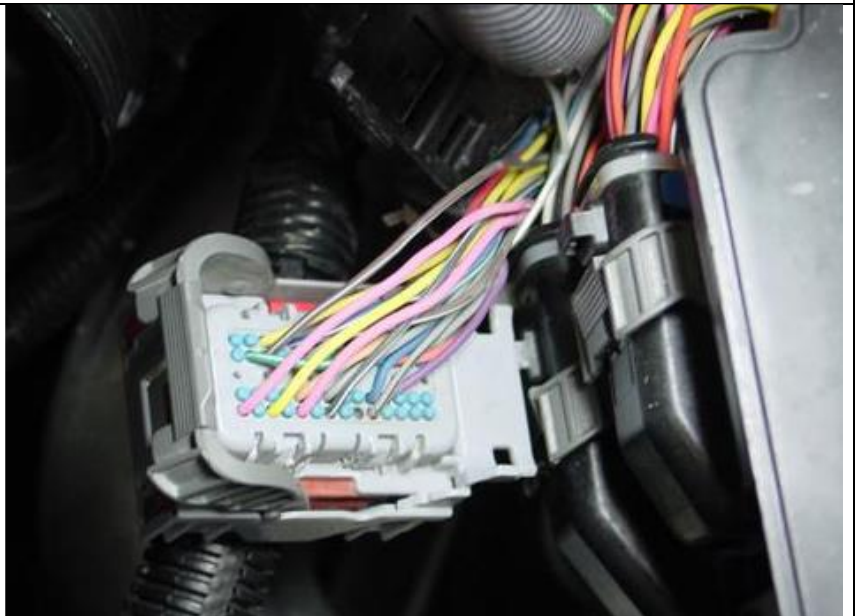

View the connector from the ECM side and ensure the pin is fully seated by comparing to adjacent pins. Lightly tug on the wire to ensure it is fully seated and locked.

Reinstall the back plastic cover on the back side of the connector. Reinstall connector into ECM.

Install supplied wire loom over the high idle kit wire from the ECM to the firewall. Secure with supplied tie wraps at the connector to reduce strain on the wire.

BD ENGINE BRAKE, INC.

Plant Address: A10-33733 King Rd, Abbotsford, BC, Canada V2S 7M9

US Shipping Address: 88-446 Harrison St, Sumas, WA 98295 US Mailing Address: PO Box 231, Sumas, WA 98295

Phone: 604-853-6096 Fax: 604-853-8749 Internet: [www.bd-power.com](http://www.bd-power.com)

Using remaining wire loom, cover the under dash wiring and secure it out of the way.

Drill hole in desired dash panel for switch using stepper bit. Ensure chosen location has sufficient room behind it for the switch body.

Install switch through hole. Reinstall knee bolster, fuse panel cover, and bezel surrounding the instrument cluster.



Reconnect vehicle batteries. Test for correct operation.

## Operation

The 2004-2005 Duramax has three high idle speeds available, 800 rpm, 1200 rpm and 1800 rpm. To operate the high idle, the engine must be running, transmission in park, foot off of the brake and parking brake set. Turn the toggle switch on to start high idle. The engine will now increase from its normal idle speed to 800 rpm. To access the higher speeds, turn on the cruise control and press either SET or RESUME/ACCELERATE. Pressing SET (button on the end of the stalk) will yield 1200 rpm, pressing RESUME (one click past the on position) will yield 1900 rpm. To stop the high idle, simply turn the toggle switch back off.



***Do not leave the high idle switch on while driving.***

The idle speeds may be adjusted using a Tech2 factory scan tool. The above engine speeds are the default values and will suffice for normal extended idling, high idle and PTO applications.

BD ENGINE BRAKE, INC.

Plant Address: A10-33733 King Rd, Abbotsford, BC, Canada V2S 7M9

US Shipping Address: 88-446 Harrison St, Sumas, WA 98295 US Mailing Address: PO Box 231, Sumas, WA 98295

Phone: 604-853-6096 Fax: 604-853-8749 Internet: [www.bd-power.com](http://www.bd-power.com)

**Troubleshooting**

Toggle Switch Not Illuminated When On	<p>Using test light, verify the fuse that has been tapped has switched ignition power.</p> <p>Check ground ring terminal connection.</p> <p>Verify toggle switch wiring is correct.</p> <p>Toggle switch lamp burnt out.</p>
High Idle Does not Function	<p>Ensure toggle switch is lit, indicating it is powered.</p> <p>Ensure the pin inserted into the ECM is fully inserted and has not backed out.</p> <p>Ensure brake lights are operating normally and brake pedal is not pressed.</p> <p>Ensure parking brake light in the instrument cluster is on when parking brake pressed, indicating the park brake switch works.</p> <p>Ensure PRNDL display does show P when transmission is in park.</p>

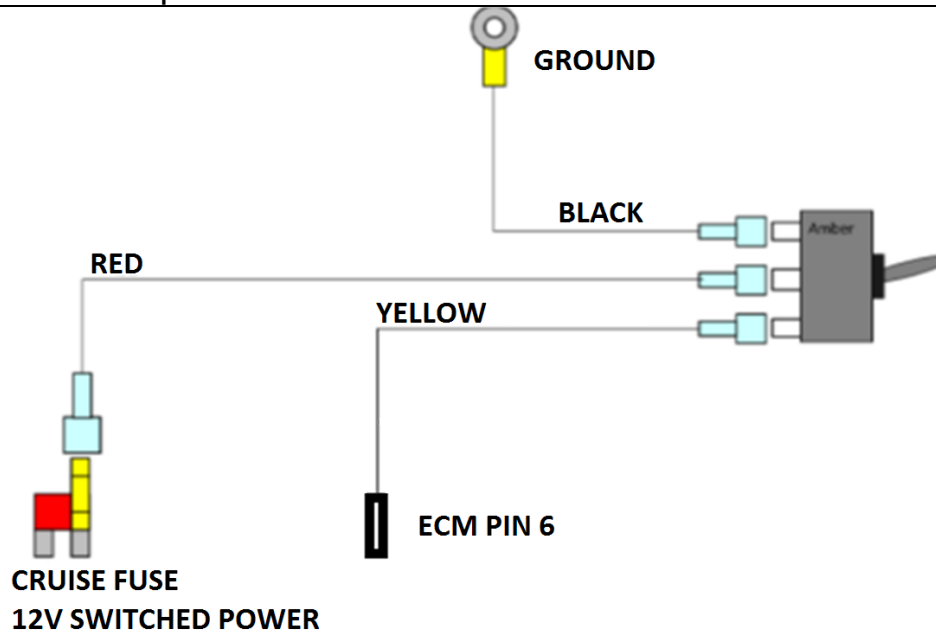

**If you have any technical difficulties, concerns, comments, or complaints, please phone our Technical Support hotline at (800) 887-5030 between 8:30am-5:00pm PST (Pacific Standard Time) Monday to Friday.**

BD ENGINE BRAKE, INC.

Plant Address: A10-33733 King Rd, Abbotsford, BC, Canada V2S 7M9

US Shipping Address: 88-446 Harrison St, Sumas, WA 98295 US Mailing Address: PO Box 231, Sumas, WA 98295

Phone: 604-853-6096 Fax: 604-853-8749 Internet: [www.bd-power.com](http://www.bd-power.com)